



Description

Self-powered and self-protected electronic siren with built-in FLASH 270°, in two shades (red and blue), for easy detection of the area from which the alarm comes. It is an ideal combination of stylish design and quality construction and is manufactured under the most, strict safety standards. The outer cover is made of high-strength polycarbonate, suitable for outdoor use. Inside it is protected by a metal cap made of galvanized sheet metal (in the Basic version) and it has protection against opening the outer lid or detaching the siren from the wall. In addition, in the IRIS PLUS / FSD version, there is a vibration detector to protect the siren from knocks and a dual infrared foam detection sensor for protection against sabotage through foaming.

General Characteristics

- In standby, the siren has seven different selectable, operating modes of the five LEDs of the FLASH.
- Five different alarm sounds (selectable) and separate sound for fire alarm.
- It has two independent activation inputs, which operate with a positive or negative voltage interruption and an independent activation input for fire detection.
- The siren will follow the alarm duration of the control panel. However, in case of interruption of or short circuit of the cables that connect the siren with the Alarm Panel an alarm will be triggered.
- Specifically:
 - Sounds an alarm with duration five (5) minutes, if the power supply cables are cut-off (+12 V)
 - Sounds an alarm with duration fifteen (15) minutes, if the TRIGGER cable is cut-off
 - Sounds an alarm with duration five (5) minutes, if the power supply cables and TRIGGER cable are cut-off simultaneously
- The siren, can be programmed so, when it starts operating will sound at low volume for 5 seconds and then the intensity will turn to normal level.
- The siren will sound an alarm of up to five (5) times in 24 hours (selectable). This time counts from the first activation of the siren and the process is canceled just spend the 24 hours or if there is siren power cut off for two seconds.
- The siren's battery voltage is verified every hour, and when it drops below 11.5V (Low Battery), the "FLT OUT" output (FAULT OUT) is activated. The "FLT OUT" output is also activated when the battery is disconnected from the siren or when its voltage drops below 10 V (Battery Fail).
- When the battery voltage exceeds 13.8 V, charging is stopped to protect the battery from overcharging.
- It has short circuit protection on the battery charging (of the cables) output. Also, it has overcurrent and short circuit protection for the battery with simultaneous activation of the "FLT OUT" output.
- It has protection against reverse connection of the battery poles with simultaneous LED indication.
- When the siren is in standby mode and its battery voltage drops below 10.0 V, siren's flash stops flashing.
- Built in TAMRER switch to protect the siren from the opening the outer casing and the detachment from the wall. The Tamper is provided with free contacts for connection to the Alarm panel.
- The FSD has a built-in 3-axis accelerometer with adjustable detection sensitivity, which, in any attempt to vandalize or change siren slope more than 45°, triggers an alarm to the siren and simultaneously triggers the output "ALR OUT" ALARM OUTPUT).
- The FSD version has a built-in foam detector, which, in any attempt to sabotage the siren with

foam fire extinguishers, polyurethane etc., triggers an alarm to the siren and at the same time also activates the ALARM output "ALR OUT".

- When the siren's supply voltage from the panel drops below 5.0 V, the "ALR OUT" output (ALARM OUT) is activated, which can be connected to a zone of the panel, so the Control panel is also triggered in case of alarm.
- The alarm duration from 3-G Sensor or foam detector is 90 seconds, and is independent of the alarm duration of the control panel.
- Through "TC" input, with a very intelligent, automated process you can isolate the TAMRER switch, the 3-G Sensor and foam detector and then you can open the cover of the siren to change the battery or make service, without the siren sound.
- The built-in FLASH has five high brightness and low power LEDs, which are short-circuit protected. The mode, the LEDs flash when the siren is in a standby mode is selectable.
- The FLASH continues to operate for 30 minutes after the end of the alarm, for easier locating of the area in alarm (selectable). This function is canceled when the panel is disarmed or when the battery voltage drops below 10.0V DC, provided that the TC input is connected to the relative output of the alarm panel.
- "SIGN" Input, with selectable visual or audible confirmation of arming or disarming of the panel, if remote control is used. This input activates the flash or the speaker, or both.

Technical Specifications	IRIS PLUS	IRIS PLUS FSD
Power Supply	13.2-14.5 V DC	
Operational Voltage	13.8 V DC	
Consumption (Standby)	8mA (when initially is powered by the battery and not by the control panel)	
Consumption (Standby)	13.0mA when the LEDs turn on at standby	
Consumption (Standby)	9.5mA when the LEDs turn on at standby	
Consumption (Alarm)	1.2A max only sound, 1.35A max when the FLASH turns on	
Consumption LED FLASH	150mA max	
Low Battery Output	When the battery voltage is lower than 11.5 V DC	
Activation from Trigger +	It is balanced when there are +12VDC on the Trigger + input. It sounds an alarm if this voltage is interrupted or if the voltage on this input drops below 5.8 V DC	
Activation from Trigger-	It is balanced when there are 0VDC on the Trigger - input. It sounds an alarm if the (-) voltage of power supply is interrupted or if the voltage on this input voltage is higher than 1.5 V DC	
Operation Frequency	900-2700 Hz	
Acoustic Power	122dB at 1 meter	
Maximum Alarm Duration	15 minutes	
Protection of the siren that is activated if the siren position angle changes more than 45° to any direction (3-axis accelerometer)	NO	YES
Anti-foam & anti-shock Protection	NO	YES
Tamper Protection	On the cover and on the wall	
TAMPER contacts (NC-NO)	600mA / 12.5 V DC	
Alarm duration from: <ul style="list-style-type: none"> • TAMPER • 3-axis accelerometer • Foam Detector 	90 seconds	
Protection Rate	IP 44	
Battery (Pb)	12 V / 1.3 ñ 2.3 Ah	
Siren housing and Flash material	Polycarbonate	
Weight (without battery)	1880 grams	
Dimensions	348 x 245 x 78 mm (WxHxD)	

Terminals Description

TAMPER COM ZONE	FREE CONTACT FOR TAMPER
REM/BUS	REMOTE BATTERY CONTROL INPUT
12V - +	POWER SUPPLY INPUT (12V) OF THE SIREN. IS ALSO USED FOR CHARGING THE SIREN'S BATTERY
TRIGGER - +	NEGATIVE OR POSITIVE ALARM ACTIVATION INPUT (PANEL CONTROLABLE)
FIRE	ACTIVATION INPUT +12V FOR FIRE ALARM
SIGN	INPUT +12V FOR AUDIBLE AND VISUAL VERIFICATION OF THE CONTROL PANEL STATUS
TC	INPUT +12V FOR TAMPER, 3-AXIS ACCELEROMETER AND FOAM DETECTOR CANCELATION
FLT OUT	LOW BATTERY OUTPUT FOR PANEL'S OR SIREN'S BATTERY (it is 0 on stand by and turns to O.C. - Open Collector)
ALR OUT	ALARM VERIFICATION OUTPUT (it is 0 on stand by and turns to O.C. - Open Collector)
SPEAKER	SPEAKER CONNECTION INPUT

Installation

To install the siren, please follow the steps, as described below:

1. Select where you place the siren, this should be as high as possible, that the siren can be easily viewed and secure.
2. Align the siren stand against the wall with the built-in spirit level, mark the fixing holes and open them with an electric drill.
3. Fix the base of the siren to the wall using the existing brackets.
4. Pass the cable connecting the siren to the panel, from the hole which is at the base of the siren. For maximum safety, prefer the passing of the cable in the inside of the siren to be directly behind this hole.
5. Connect the siren to the panel, as explained in the connection terminals on page 5 and the following wiring diagram.

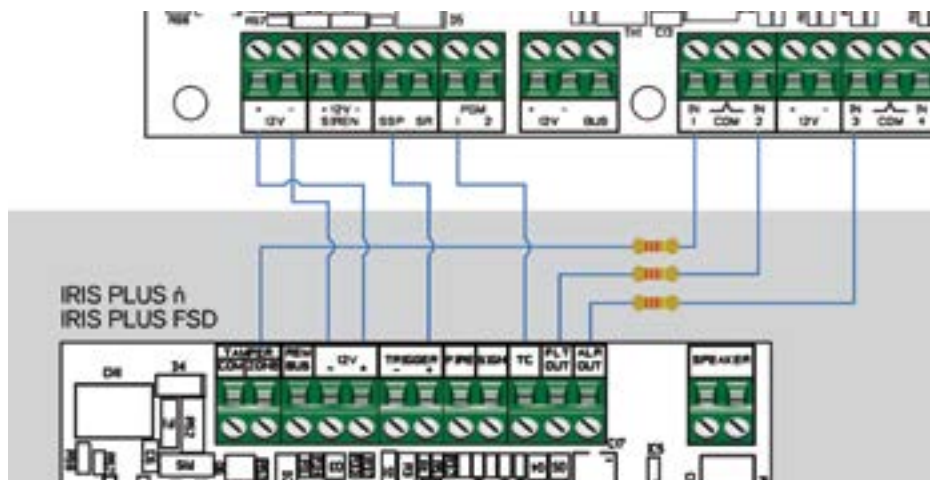

6. When you finish cable connections, connect the battery to the siren. The siren can remain in this condition until you finish the installation. The siren will start to operate normally only when supplied with power from the alarm control panel.



Note:

When the power supply is initially applied from the panel to the siren, a short sound will be heard as a confirmation that the siren has been activated.

7. Insert the inner cover and fasten it with four corresponding screws
8. Close siren's external cover and fasten it with the corresponding screws.



Attention!

To power the siren from the alarm panel, you must, definitely, use wire with diameter 0,5-0,75mm². It is recommended to use cable 2x0,50 + 4x0,22 mm².

Selecting the Siren's Operation Mode

The siren's operation mode, in addition to the settings you should do, as described in the following sections, has to do with the options of the wiring to the control panel, as detailed below.

1. Selecting the way in which the TAMPER of the siren will trigger alarm

The siren's tamper activates the siren and the "TAMPER" output simultaneously. If you do not wish the siren to be activated and only the "TAMPER" output to be activated, you can program as described in the corresponding section on page 10.

The Tamper contacts end up to the "TAMPER" output of the siren. When the siren is screwed to the wall and its lid is closed, this output is NC and becomes NO when the lid is opened or the siren is detached from the wall. These contacts can be connected to any direct or 24-hour zone of the panel (like NC or EOL zone, using EOL resistor), **taking care to use the correct polarity (COM & ZONE).**

- If you use an EOL zone, then, for greater security, place the EOL resistor in the siren at the TAMPER ZONE output and in series with the cable as shown in the wiring diagram (page 6).

2. Remote test of the siren

The input "REM-BUS" is used to remotely control the status of the siren's battery. At this input you have to transmit 12.0V every time you wish to test the battery. By applying the 12.0 V to this input, the "FLT OUT" error output opens to confirm receipt of the Remote Test command. At the same time, the battery status test starts. If there is no problem with the battery, the "FLT OUT" output will remain open for only 10 seconds and then be deactivated. If a fault is detected on the battery, the "FLT OUT" output will remain activated after the end of 10 seconds and until the fault is restored. Once the fault is restored, another test will be carried out and, if the test does not detect a problem, the "FLT OUT" output will be deactivated.

3. Power Supply of the siren

The + 12V inputs are for providing power supply to the siren and for charging the siren's battery. They are connected to the corresponding outputs of the panel, **taking care to use the correct polarity.**



Attention!

For security reasons and for the proper operation of the siren, a battery must in any case be used. In the case, however, that you want the siren to operate without a battery, you must connect the red battery cable to + 12V input of the siren.

4. Select the siren's indication activation mode

The TRIGGER (+ or -) inputs are used for the activation of the siren. Activation can be done with one of the following two ways:

A. Interruption of positive voltage

Connect the "+ TRIGGER" input of the siren to the corresponding output of the panel or a programmable output (PGM), which must provide 12.0V at standby and turn to 0 when an alarm is activated.

B. Interruption of negative voltage

Connect the "- TRIGGER" input of the siren to the corresponding output of the panel or to a programmable output (PGM), which must have 0V at standby and turns to Open Collector or turns to 12.0V when an alarm is activated.

- The siren follows the alarm duration of the table. However, in the event that the cables connecting it to the panel are cut or shorted, the siren will sound an alarm of maximum 5 minutes.

5. Fire Alarm Activation Input

The **“FIRE”** input is used to activate the siren in the event of a fire alarm. It is activated by applying a voltage of +12 V and the siren sounds with a special fire detection sound.



Attention!

If the **“TRIGGER”** and **“FIRE”** input are activated at the same time, the **“FIRE”** input will have priority

6. Bypassing the Siren’s Tamper - Removing the Lid

“TC” input (Tamper Control input) is used to deactivate the siren’s Tamper, when you open the cover of the siren for service, without given an alarm. Connect **“TC”** input to a **“PGM”** output of the alarm control panel, which provides 12 V at standby mode and goes to 0 when the panel arm. The presence of 12V on this input disables the Tamper of the siren for 10 minutes.

- In the Sigma Alarm panels, connect the siren’s TC input to a PGM, which must be programmed as type 27.

7. Visual or audible indication input

The **“SIGN”** input is used when we want to have visual and / or audible indication of arming or disarming the panel via the siren when, arming or disarming the system by remote control. It is activated as long as there is +12 V at its input and is connected to a programmable output of the panel (PGM) which is programmed accordingly.

- In the Sigma Alarm panels, it must be connected to a PGM programmed as type 29.

8. Fault Output

The siren automatically monitors the battery status (Battery Self-Test) by dynamically testing the battery, every hour when there is a voltage at the siren power input (+ 12V-) or, every five minutes when there is no voltage. If, during the test, the battery voltage is lower than 11.5V, we have a low battery voltage indication, and if the battery voltage is below 10.0V, we have a battery failure indication. In both cases, the **“FLT OUT”** (Fault Output) output is activated.

The **“FLT OUT”** output is 0V and becomes Open Collector (OC) when the battery voltage is low or the battery is damaged. Returns to standby again at the next test and if the battery voltage rises above 11.5V or the battery is replaced with a new one.

This notifications are used to inform the user and / or the Central Monitoring Station, the battery status of the system. A LED may be connected to this output or it may be connected to the control panel, as shown in the siren wiring schematic.

- For greater security, program the Control panel zone as a 24-hour EOL and connect the terminal resistor in the siren.

9. Alarm Output

The **“ALR OUT”** (**Alarm**) output is activated when the siren triggers an alarm if its power supply voltage from the Alarm panel is interrupted, or the foam, shock or 3-axis detector is activated.

The **“ALR OUT”** is activated simultaneously with the siren and is 0 at standby and becomes Open Collector (OC) on activation. Used to update the system user and notify the Central Monitoring Station for this event. You can connect it to a LED indicator or a zone of the panel, programmed accordingly, as shown in the schematic that displays the siren connection.

- For more safety, program the zone as EOL and place the EOL resistor of this zone inside the box of the siren.

Programming

The programming of siren functions is done via the “MENU” and “SELECT” buttons, which are placed on the siren board.

- Use the “MENU” button, to select the programming step you need. Each time you press “MENU” button, you select different programming mode and this is indicated by lighting the relative LED.
- Use the “SELECT” button to select the parameters of each sub “MENU”. Every time you press “SELECT” button you change a parameter. If you have missed the desired parameter just press “SELECT” button, as many times it is needed to return to the parameter you need.

Enter Setup

To enter the siren MENU, power the siren by connecting the battery to the corresponding terminals, taking care to use correct polarity. Then **leave the siren’s Tamper open** and press and hold the “MENU” button until the confirmation signal (five beeps) is heard and the “SOUND” LED turns on.

Now the siren is in the programming mode and the settings you can make are indicated by turning on the corresponding siren LEDs.

Siren Sound selection

To select the siren’s sound, press “SELECT” button, when the LED “SOUND” lights. Each time you press “SELECT” button, the siren’s sound will change. This sound will come out of the siren’s speaker in low volume. The last sound you hear will be the new sound of the siren.

- Press “MENU” to save settings and navigate to next menu. The LED with “FLASH” indication will turn on.

Select the siren’s lighting at standby mode

When the LED “FLASH” lights, use “SELECT” button, to select the lighting mode of the siren at standby or **even disable it**. Each time you press “SELECT” button, will change the format of movement of the siren’s LEDs will be the one the siren will have. The form of movement that, you will see at the LEDs, is the one, the siren will follow. **If all the LEDs are off then, the siren will have no lighting at standby mode.**

- To store this setting into memory, press the MENU button. The LED with the indication “L/S” will turn on.

Select the siren’s indication of arming or disarming of the system

Once the LED “L/S” lights, press “SELECT” button to select how they will be displayed through siren signaling the arming and disarming of the system. Each time you press “SELECT” button, will illuminate the LEDs “SOUND” and “5/24” or the siren will sound or both. In any of these cases you stay, this will be the way in which the siren will signal arming or disarming of the system.

- Press “MENU” to save settings and navigate to next menu. The LED “Hi-Lo” will light. In factory default setting only, Flash will indicate arming and disarming of the system.

Select the level of the siren sound at the start of alarm (pre-alarm)

Once the LED “**Hi-Lo**” lights, press the SELECT button to select the level of the siren sound at the start of the alarm. Each time you press SELECT button, the siren will sound with high or low sound level (Hi-Lo). If you select low sound level, the siren will sound at low volume level for 8 seconds at the beginning of its operation and then gives all its intensity. If you select high sound level, the siren will sound with all its intensity in case of alarm. (factory programming)

- Press “MENU” button to save your setting and navigate to next selection. The LED with the indication “**5-24**” will light.

Select the number of siren’s activations during twenty-four hours (maximum daily alarms)

As soon as the LED “**5-24**” lights, press “SELECT” button to select if the siren will sound every time the alarm system is activated or only five times during a twenty-four hours (the duration of each alarm should be longer than 20 seconds). Each time you press “SELECT” button, you will hear the sound of the siren and will turn on or turn off all five LEDs of the siren. If you choose the situation has light up all five LEDs, then the siren will alarm up to five times during the day. If you chose the situation with five LEDs turned off, then the siren will operate always, repeatedly if an alarm is given (factory programming).

- Press “MENU” button to save your setting and navigate to next selection. The LEDs “**SOUND**” & “**5/24**”, will light simultaneously.

Select the siren’s activation from Tamper

As soon as the LEDs “**SOUND**” & “**5/24**” light press “SELECT” button to select if the siren’s Tamper, will activate the “**Tamper**” output, but it will activate the siren, also. When the brightness of these LEDs is low, “**Tamper**” does not activate the siren but only the “**Tamper**” output while when the brightness of the LEDs is high, Tamper simultaneously activates the Tamper output and the siren (factory programming).

- Press “MENU” button to save your setting and navigate to next selection. The LEDs with the indications ενδείξεις “**FLASH**” & “**Hi-Lo**”.

Adjusting siren sensitivity to blows (Only in IRIS PLUS FSD)

When the LEDs with the indication “FLASH” & “Hi-Lo” will turn on, use the button SELECT to adjust the siren’s sensitivity to blows which are detected by the 3-Axis accelerometer. Each time you press “SELECT” button, you will turn on or turn off one or more of the five LEDs, which show the sensitivity of the siren in blows. **When all five LEDs are turned off, this function is deactivated it remains, however, active detection of inflection.**

- To store this setting into memory, and navigate to the next menu, press the MENU button. The LEDs with the indication “**FLASH**” & “**Hi-Lo**”, will turn on

Adjusting siren sensitivity to drilling (Only in IRIS PLUS FSD)

When the LEDs with the indication “FLASH” & “Hi-Lo” turn on, use the button SELECT to adjust the siren’s sensitivity to drilling which are detected by the 3-Axis accelerometer. Each time you press “SELECT” button, you will turn on or turn off one or more of the five LEDs, which show the sensitivity of the siren to drilling. **When all five LEDs are turned off, this function is deactivated.**

- To store this setting into memory, and navigate to the next menu, press the MENU button. The LEDs with the indication **"FLASH" & "L/S" & "Hi-Lo"**, will turn on.

Selecting the Foam detector function (Only in IRIS PLUS FSD)

As soon the LEDs **"FLASH" & "L/S" & "Hi-Lo"**, light, press **"SELECT"** button to select if the foam detector will be active or inactive. Every time you press **"SELECT"** button, will increase or decrease the brightness of the three LEDs. When the LEDs have a low brightness, the foam detector will be deactivated and when the light level is high the foam detector will be activated.

- Press **"MENU"** button to save your setting and navigate to next selection. The LED **"SOUND"**, will light to indicate you are in the first step of setup.

Exit Setup

To exit setup press continuously **"MENU"** button until you hear the confirmation sound (5 BEEPs). Immediately, the LEDs **"SOUND" & "5-24"** will turn on for 1 second and the siren will enter standby mode.



Note

Also, the siren exits programming and returns to standby mode, after three minutes without pressing any of the two buttons.

Factory Programming

Resetting the factory settings is done when the siren is in a standby mode. To restore the factory settings, simultaneously press the MENU and SELECT buttons for three seconds until you hear the confirmation signal (five BEEP). Then the LEDs with **"SOUND"** and **"5-24"** indication will flash for one second and the siren will return to Standby mode.

Opening the siren (Engineer Mode)

This function allows you to open the siren for maintenance or to change the battery without the siren being activated by the tamper. A prerequisite is that the **"TC"** input of the siren has been connected to the panel, as described in the chapter on Selecting the siren's Operation Mode, in the section **"Bypassing the Siren's Tamper - Removing the Lid"**.

Whenever you wish to open the siren when it is installed and connected to the Alarm panel, follow the procedure below:

- As soon as you have connected the siren's TC to the corresponding output of the panel, activate the corresponding PGM of the panel or, in the case of a Sigma panel, arm and immediately disarm the panel to apply + 12V to the TC input. When you do the above, you have ten minutes to open the siren lid without activating an alarm, because Tamper is inactive for that period. After opening the lid, the time that the siren may remain open becomes unlimited and is reset when the siren lid is closed again.
- Upon completing service, close the lid and secure it with the corresponding screws. As soon as you close the lid, the two siren LEDs will light for five seconds, and when a minute has elapsed since you close it, the siren will return to normal operation and Tamper will be active again. Also, for security reasons, siren's Tamper is always active, as soon as 10 minutes have elapsed since the voltage is applied to the TC, without opening the lid.

Commissioning

You must regularly test the siren operation. Thus, you will make sure that the siren is functioning properly and will sound in case of alarm.

1. Check the proper operation of the siren's speaker as well as the LED Flash by simulating an alarm from the Control Panel.
2. Check the proper functioning of Tamper switch that protect the siren from opening or detachment from the wall.
3. Check whether the siren's battery voltage is 13.2-13,8 V. If the battery voltage is lower than this, replace the battery and connect the new battery, keeping in mind to use the correct polarity.
4. Check for signs of water or insects entering the siren and clean if necessary.

RECYCLING

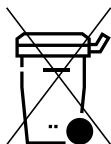

Do not dispose of this device or battery in a household waste bin!

- The electrical and electronic equipment used must be handled separately and in accordance with the legislation, which requires appropriate processing and recycling of the aforesaid goods.
- The battery contains pollutants and, therefore, after the end of its lifetime, it should not be disposed of in common waste but delivered to the appropriate operator for the collection and disposal of polluting waste in accordance with the local laws and regulations.
- Recycling of the product will help to avoid potential adverse effects on the environment and human health, which could arise from inadequate waste management.

Warranty

Thank you for selecting our products which have been designed and manufactured to offer you security and safety for many years. They have been thoroughly tested before reaching your hands, and have passed all necessary performance tests. **All our products are covered by a 6 (SIX) years warranty, for good operation**, from the date of purchase and covers the products that are accompanied by invoice or receipt of purchase. This warranty covers the free of charge repair of the device (parts and labor) in case the malfunction is due to failure of device itself and not if the failure is cause to any wrong installation, improper use or external factors such as lightning, floods, excess power voltage etc. **Warranty ceases to exist** if the device has been installed or repaired by an unauthorized person. Also, this warranty does not cover the losses, failures or injuries that might happen to the secured area, in case of miss operation of the device. Finally, our company is not responsible for the correct installation and use of the security system, for which solely responsible is the installer.



www.sigmasec.gr